

Bridge belt conveyor system

2x on Stock

PTB-BOA feeder

- Length 16 m
- Belt width 800 mm
- Flame retardant belt, runners
- Can be controlled and switched from a roadheader
- With additional short version of segment
- Efficiency 420 t/h, belt speed 2,5 m/s. PTB-BOA
- Power drive 1x18 kW, 950V, 60 Hz with strengthened gearbox







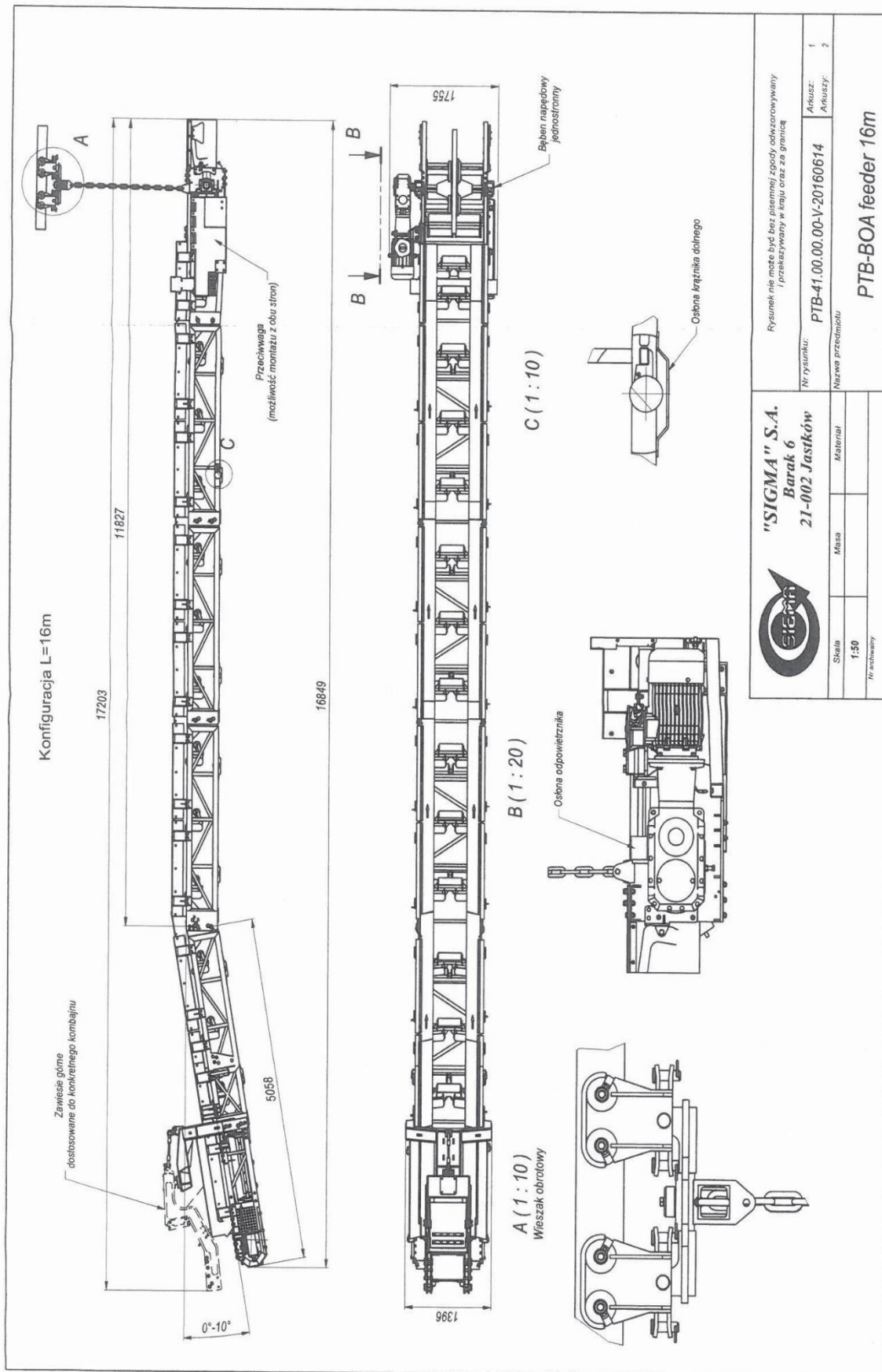

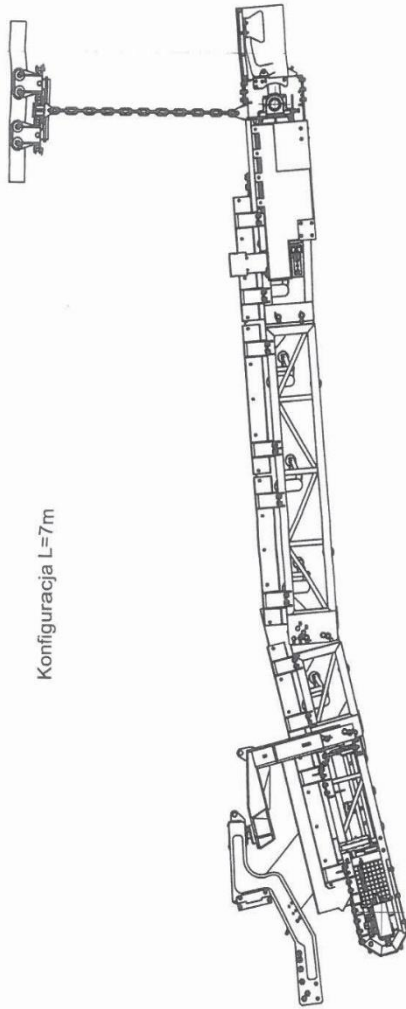

 "SIGMA" S.A. Barak 6 21-002 Jastków		Rysunek nie może być bez pisemnej zgody odwzorowywany i przekazywany w kaju oraz za granicę	
		Nr rysunku: PTB-41.00.00.00-V-20160614	Arkusz: 1 Arkuszy: 2
Masa	Materiał	Nazwa przedmiotu PTB-BOA feeder 16m	
Skala 1:50	Nr archiwalny		

Konfiguracja L=7m

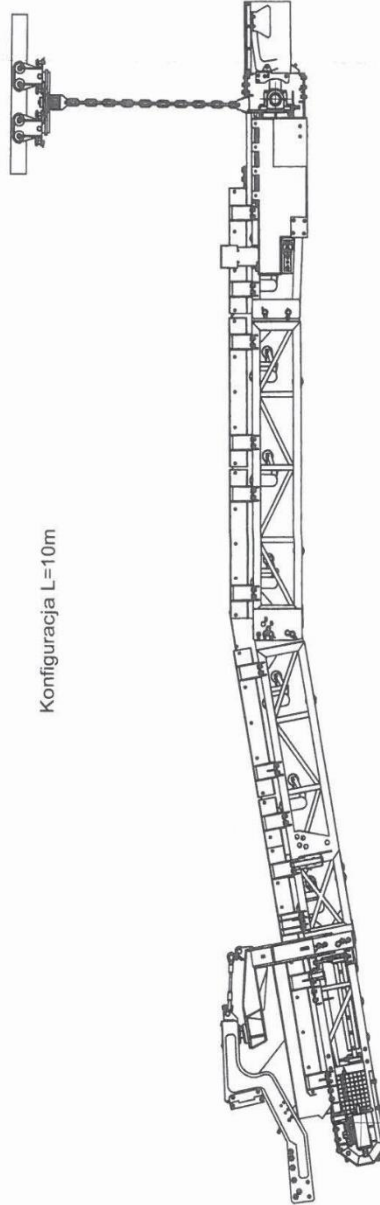

Konfiguracja L=10m



		"SIGMA" S.A. Barak 6 21-002 Jastków		Rysunek nie może być bez pisemnej zgody odzorowywany i przekazywany w kraju oraz za granicą	
Skala	Masa	Materiał	Nr rysunku:	Nr rysunku:	2
1:40			PTB-41.00.00.00-V-20160614	Artuzi:	2
Nr archiwowy			Nazwa przedmiotu PTB-BOA feeder 16m		

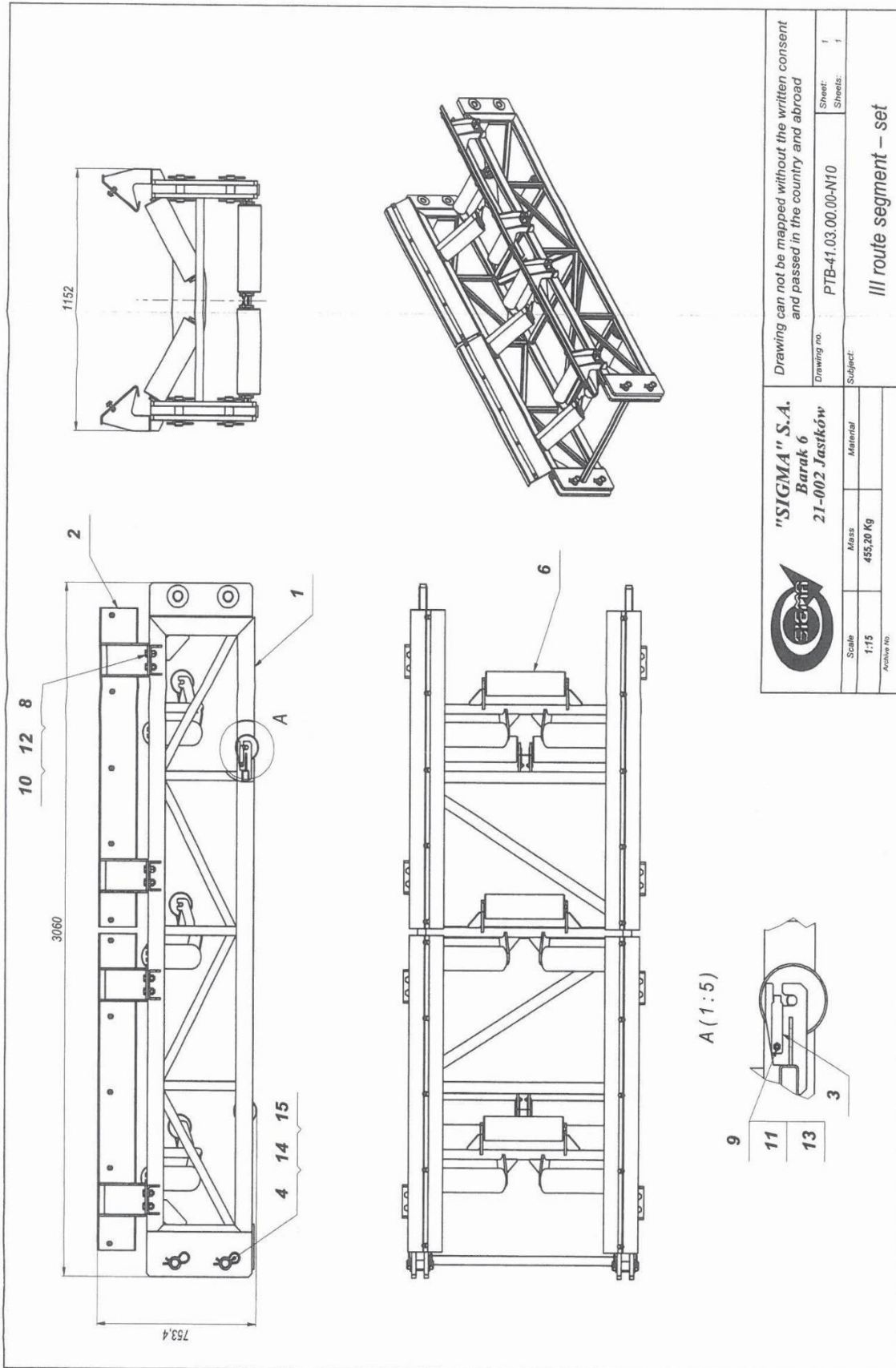

		"SIGMA" S.A. Barak 6 21-002 Jasków		Drawing no. PTB-41.03.00.00-N10 Sheet: 1 Sheets: 1	
Scale	1:15	Mass	455,20 Kg	Subject: III route segment - set	
Material		Archive No.			

Drawing can not be mapped without the written consent and passed in the country and abroad

